

Genkotsu-Robot 2 High Speed Picking and Assembly Robot

FANUC Robot *M-2iA*



Features

- The FANUC *M-2iA* robot is a high-speed picking and assembly robot.
- Four models are available to meet the needs of multiple space requirements.
 - FANUC Robot *M-2iA/3S*
Four-axis model with a single-axis wrist. This model is designed for picking from a conveyor at extremely high rates.
 - FANUC Robot *M-2iA/6H*
Three axis model with no wrist rotation for ultra high speed picking/packing operations.
 - FANUC Robot *M-2iA/3SL*, *M-2iA/6HL*
Long-arm model covers a wider operating area.
- Able to withstand high-pressure steam cleaning - IP69K rating.
- Food adaptation option is available with a high-quality surface treatment and food-grade lubricant, making it ideal for handling food and beverage products.
- Ready to be equipped with the latest intelligent features including FANUC *iR*Vision and force sensing.

Application system



Food picking with four-axis *M-2iA/3SL*

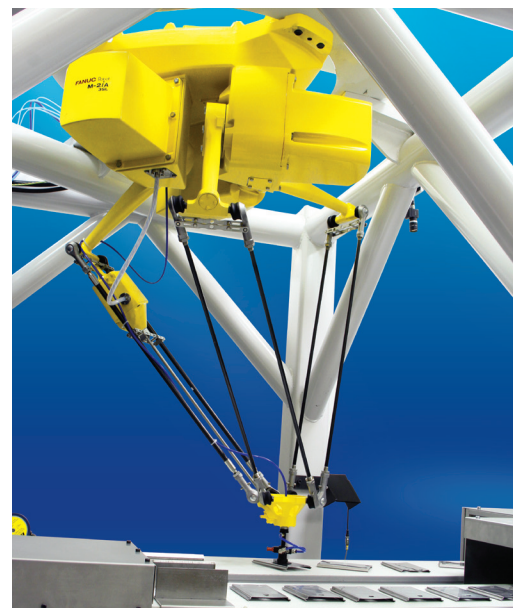

High speed sorting of metal plates with long-arm *M-2iA/3SL*

M-2*i*A/3S
M-2*i*A/6H

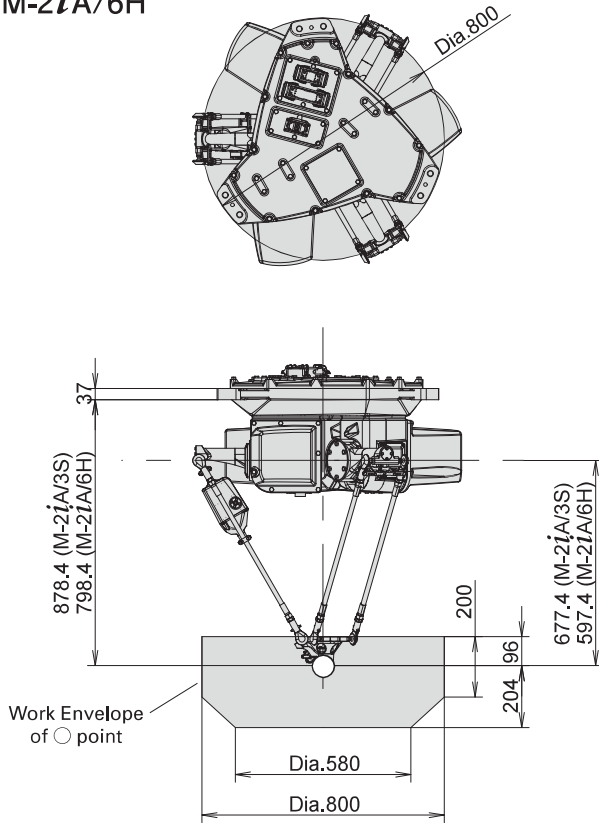

M-2*i*A/3SL
M-2*i*A/6HL

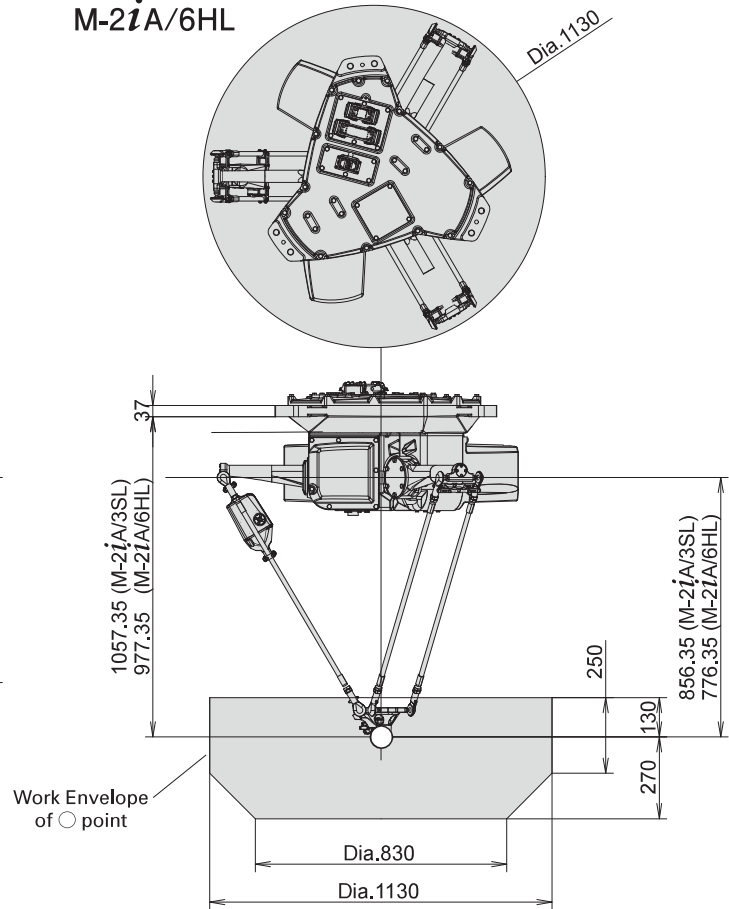

Specifications

Item	Specifications	
	M-2 <i>i</i> A/3S, M-2 <i>i</i> A/3SL (Note3)	M-2 <i>i</i> A/6H, M-2 <i>i</i> A/6HL (Note3)
Type	Parallel link mechanism	
Controlled axes	4 axes (J1, J2, J3, J4)	3 axes (J1, J2, J3)
Installation	Ceiling mount	
Motion range(Maximum speed)	J1-J3	Diameter 800mm, height 300mm (Note3 Diameter 1,130mm, height 400mm)
(Note1)	J4	720° (3500°/s) 12.57 rad (61.06 rad/s)
Max.payload at wrist	3kg	6kg
Repeatability	±0.1mm	
Drive method	Electric servo drive by AC servo motor	
Mass (Note2)	120 kg	115 kg
Installation environment	Ambient temperature : 0~45°C Ambient humidity Normally : 75%RH or less (No dew, nor frost allowed) Short term : Max. 95%RH or less (within one month) Vibration : 4.9m/s ² (0.5G) or less	

Note 1) In case of short distance motion, the axis speed doesn't reach maximum speed.

Note 2) Without controller.

Note 3) For long arm specification (M-2*i*A/3SL, M-2*i*A/6HL)

FANUC

FANUC AMERICA CORPORATION
3900 WEST HAMLIN ROAD
ROCHESTER HILLS MI 48309-3253

